

VEVOR[®]

TOUGH TOOLS, HALF PRICE

Technical Support and E-Warranty Certificate

www.vevor.com/support

SLUSH MACHINE

MODEL: XRJ3LX1 XRJ3LX2

We continue to be committed to provide you tools with competitive price. "Save Half", "Half Price" or any other similar expressions used by us only represents an estimate of savings you might benefit from buying certain tools with us compared to the major top brands and does not necessarily mean to cover all categories of tools offered by us. You are kindly reminded to verify carefully when you are placing an order with us if you are actually Saving Half in comparison with the top major brands.

VEVOR[®]

TOUGH TOOLS, HALF PRICE

SLUSH MACHINE

MODEL: XRJ3LX1 XRJ3LX2



NEED HELP? CONTACT US!

Have product questions? Need technical support? Please feel free to contact us:

Technical Support and E-Warranty Certificate
www.vevor.com/support

This is the original instruction, please read all manual instructions carefully before operating. VEVOR reserves a clear interpretation of our user manual. The appearance of the product shall be subject to the product you received. Please forgive us that we won't inform you again if there are any technology or software updates on our product.



Warning-To reduce the risk of injury,user must read instructions manual carefully.



CAUTION: Changes or modifications not expressly approved by the party responsible for compliance could void the user's authority to operate the equipment!

This device complies with Part 15 of the FCC Rules. Operation is subject to the following two conditions:

- 1) This product may cause harmful interference.
- 2) This product must accept any interference received, including interference that may cause undesired operation.

WARNING: Changes or modifications to this product not expressly approved by the party responsible for compliance could void the user's authority to operate the product.

Note: This product has been tested and found to comply with the limits for a Class B digital device pursuant to Part 15 of the FCC Rules, These limits are designed to provide reasonable protection against harmful interference in a residential installation.

This product generates, uses and can radiate radio frequency energy, and if not installed and used in accordance with the instructions, may cause harmful interference to radio communications. However, there is no guarantee that interference will not occur in a particular installation. If this product does cause harmful interference to radio or television reception,which can be determined by turning the product off and on, the user is encouraged to try to correct the interference by one or more of the following measures.

- Reorient or relocate the receiving antenna.
- Increase the distance between the product and receiver.
- Connect the product to an outlet on a circuit different from that to which the receiver is connected.

	<ul style="list-style-type: none"> • Consult the dealer or an experienced radio/TV technician for assistance.
	<p>This product is subject to the provision of European Directive 2012/19/EC. The symbol showing a wheeled bin crossed through indicates that the product requires separate refuse collection in the European Union. This applies to the product and all accessories marked with this symbol. Products marked as such may not be discarded with normal domestic waste, but must be taken to a collection point for recycling electrical and electronic devices</p>

Instructions

Thank you very much for choosing this slush machine. Slush machine is a kind of machine and equipment widely used in the food industry and catering industry, it is mainly through the frozen juice, milk or yogurt and other beverages frozen into a sorbet, and will be cut into fine particles through the scraper, made of soft taste snow ice! Please read all of the instructions before using it. The information will help you achieve the best possible results.

Contents

- 1. Introduction
 - 1.1 Manufacturer
 - 1.2 Operator
 - 1.3 Manual distribution
 - 1.3.1 Function and content
 - 1.3.2 Who to read manual
 - 1.3.3 How to keep manual
- 2. Machine description
 - 2.1 Usage

- 2.2 Main Component
 - 2.3 Technical data
 - 2.4 Control panel
 - 3. Safety manual
 - 4. Transportation and storage
 - 4.1 Packing
 - 4.2 Transportation
 - 4.3 Storage
 - 5. Installation
 - 5.1 Parts list
 - 5.2 Position to install
 - 5.3 Handling package material
 - 5.4 Connect power
 - 6. Operation
 - 6.1 Preparing material and stirring evenly
 - 6.2 Starting a 1-bowl Slush Machine Model: XRJ 3L*1
 - 6.3 Starting a 2-Bowl Slush Machine
 - 6.4 Dispensing slush
 - 6.5 Emergency
 - 7.1 Empty Bowl
 - 7.2 Disassembling the dispensing tap
 - 7.3 Move out bowl and cover
 - 7.4 Clean and disinfect parts
 - 7.6 Clean step
 - 7.7 Cleaning drip tray
 - 7.8 Replace bulb
 - 7.9 Clean condenser
 - 7.9.1 Cleaning condenser of one-bowl slush machine
 - 7.9.2 Cleaning condenser of two-bowl slush machine
 - 7.10 Scheduled maintenance
- 8. Waste treatment
 - 9. Troubleshooting
 - 9.1 Fault Codes and Solutions For Slush Machine

- 9.1.1. When the temperature is connected, "LL" is displayed
- 9.1.2 The temperature is short-circuited and it displays "LL"
- 9.1.3 When the grid voltage is too high, the machine stops working and generates an alarm code "E1 Err"
- 9.1.4. When the grid voltage is too low, the machine stops working and generates an alarm code "E2 Er"
- 9.1.5. The measured motor current is too high, the current channel generates an alarm and protects shutdown, the display code is E3 Err
- 10. Intelligent electronic valve system
- 11. Slush machine explosive diagram

1. Introduction

1.1 Manufacturer

The manufacturer's details are shown on the identification plate

1.2 Operator

Based on different applications, there are two types of persons.

User

In accord with Health standard people trained compel techniques,
 Know all to distribute slush have below ability after reading this manual :
 Place and change slush machine Properly dispensing the products
 Cleaning the slush machine
 Specialized technical people
 Studied this manual and trained how to install, use and maintain this slush machine;
 When serious fault, can repair the slush machine and know this manual well
 Master all information of the manual and can explain the diagrams and graphs correctly;
 Know important hygienic knowledge well, prevent accident concurring, know technical and safety standard
 Have experience to serve this kind of slush machine.

Master treatment measure to emergency. ind separated safety device and use the machine correctly



People are banned to use the machine who do not accord with above requirement

1.3 Manual distribution

Users have to read this manual carefully before using.

1.3.1 Function and content

Offer vital information of using and installing

1.3.2 Who to read manual

Users and specialized technical people.

This manual is an inseparable part of the machine.

So it needs to be delivered to the purchaser when sold.

1.3.3 How to keep manual

Manual has to be placed nearby the machine and keep intact and clear

2. Machine description

2.1 Usage

This machine is specially used for making slush. If used to make dairy and other foods, bowl material temperature needs to be tested and abide by the machine's current regulation and standard

2.2 Main Component

1.Bowl roof 2.Bowl 3.Control panel 4.Drip tray 5.Drip tray cover	6.Drain hose 7.Tap 8.Handle 9.Machine foot
--	---

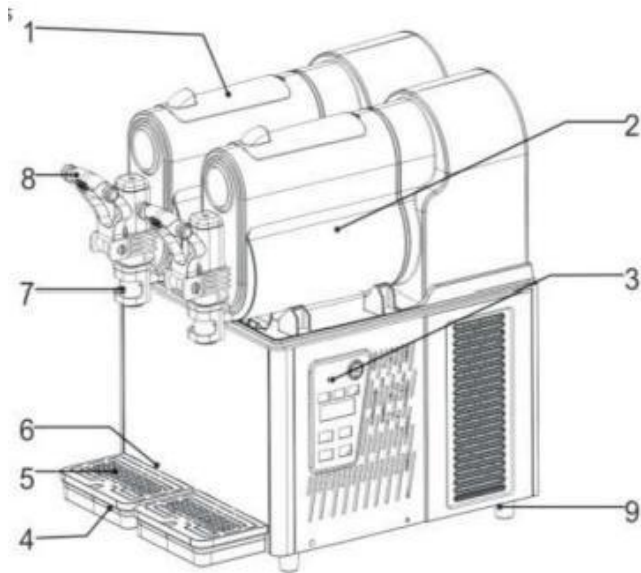

In this manual, the items mean as below

XRJ3LX1, one-bowl slush machine

XRJ3LX2, two-bowl slush machine

2.3 Technical data

Mode	XRJ3LX1	XRJ3LX2
Size L*D*H (CM)	20X51x52	36X51x51.5
Net weight (kg) (Bowl empty)	See nameplate	
Power (w)	See nameplate	
Liquid Temperature	Min:20°C/68 °F Max:32°C/89 °F	
Bowl	1	2
Bowl (L)	3	6
Operating Noise	<65 decibel	
Climate	N	



Any change or increase has to be approved and executed by
Manufacture.

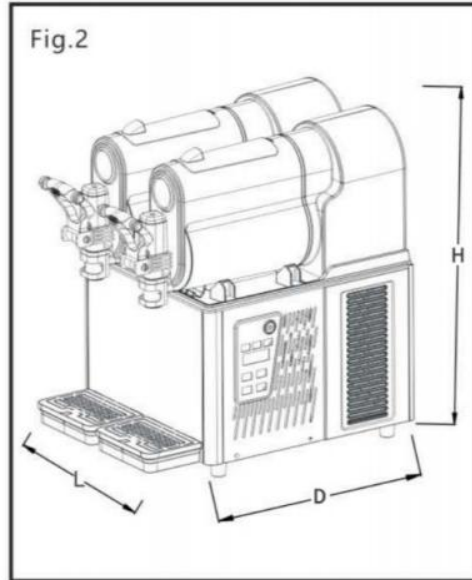

2.4 Control panel

Fig.3





3. Safety manual

Slush machine parts and condenser's installation, slush machine troubleshooting exclusion and maintenance to be operated by manufacturer professional people who have related experience. Without experienced people monitoring or guiding, slush machine cannot be used by disabled, sense disable, mental disable people who's lack of experience and knowledge. Children need to be taken care when playing nearby the machine. When machine's wire broken, they have to be replaced by manufacturer professionals or people who have related experience. When machine scraped, it has to be delivered and handled by related authority institution.

4. Transportation and storage

4.1 Packing

Wooden box, contoured foam & collect.
 Packing size (approximate)

	Width(L)	Depth(D)	Height(H)
XRJ3LX1	310mm	700mm	720mm
XRJ3LX2	460mm	695mm	740mm

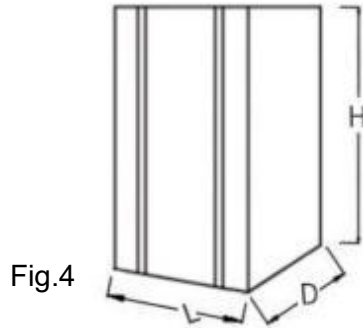

Remarks: packing size and weight are approximate.

4.2 Transportation

Keep up ward and carried by two people at least.

4.3 Storage

Notice: please do not exceed three layers.



5. Installation

The slush machine has to be installed indoor with hard and plain ground under enough light and ventilation (Ground inclination can't be more than 2 degree)

5.1 Parts list

After cleaning and disinfecting all indicated parts in manual have to be coated with lubricating oil.

5.2 Position to install

Installation position have to be planed in advance;

Installation place have to be hard and plain

Installation condition is enough light and ventilation and clean; Power socket is also needed;

Installation distance from other objects see below fig.6

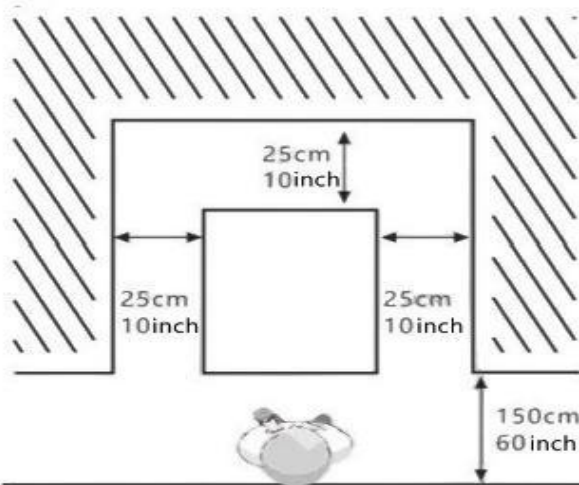

Fig.6

5.3 Handling package material

Handling packing material separately under local rules and we suggest keep it to repack and ship in future.

5.4 Connect power

Ensure slush machine is off before connecting power. Then plug in to connect power.

Data can be referred from machine back nameplate.

Warning: Socket has to be placed within user touching distance in order to unplug quickly when emergency without using other tools.

6. Operation



Warning

Frozen Drink (Percentage of juice powder: $\geq 10\%$)	SLS 01 32°F~44.6°F (0°C~7°C)
Slushy (Percentage of sugar: $\geq 15\%$)	SLS 02 - SLS 05 28°F~23°F (-2.2°C~-5.2°C)
Margarita Wine Slush (Percentage of liquor :10%-45%)	SLS 06 - SLS 15 21°F~9°F (-6.2°C~-13°C)

Note:

- 1.The liquor generally refers to be 40%alcohol by volume.
- 2.The SLS xx will blink when the gear is adjusted and the machine will automatically save the setting after 5 seconds. After that the display stops flashing and the temperature of the liquid in the cylinder is displayed in the form of Fancy Celsius,e.g.xx F.
- 3.When the temperature inside bowls is very low,there will be frosting on the outside of the bowls,which is normal.
4. At low temperatures,the spout may freeze.Just cast a brush toward the spout and the slush/margarita wine slush/ice cream will flow out properly.

6.1 Preparing material and stirring evenly

Only water is prohibited

Attention

Operate under Manufacturer direction;

Dilute and stir concentrated liquid with water in a container

Mixture sugar content should >15%

lower content will damage the augers and gear motors



Fig.7

If you need to make alcohol slush, pour appropriate percentage of alcohol into the container according to your needs

Remove the lid as below steps

1. Lift the top lid;
2. Pour the material into bowls





Warning

Hot liquid can not be put in (hot liquid means degree exceed 40°C)

Material level can not exceed maximum height level

3. Close the top lid after pouring the material

 	<ol style="list-style-type: none">1. Warning: Before connecting power or starting machine, put material into bowl2. Material can not just be water.3. Warning: Banning petting hand in bowl machine is working
--	--

6.2 Starting a 1-bowl Slush Machine Model:XRJ3LX1

The following controls are on the panel:

A. Main Switch  : It is used to switch on/off the power supply to the whole machine.

B. Light Switch  : It is used to switch on/off the light.

C. Clean Function: Add appropriate water in advance, then clicking the "SET" switch" , until the display shows "CLEAN" that means open Clean System. After cleaning,

click the SET switch  once more, the display shows "OFF" that means close Clean System. When the cracks aren't clean, use the provided towel to clean any remaining dirt and wipe up any water stain.

D. Slush/Margarita Wine Slush/Ice Cream/Frozen Drink Function: Keep clicking the SET switch  display shows SLS that is used to switch on Slush System.

Then you can click "+"  to make slush/ice cream

harder and can also click "-"  to make slush/ice cream softer. The machine will automatically save the setting after 5 seconds.

6.3 Starting a 2-Bowl Slush Machine Model: XRJ3LX2

The following controls are on the panel:

A. Main Switch  : It is used to switch on/off the power supply to the whole machine.

B. Light Switch  : It is used to switch on/off the light

C. Clean Function: Add appropriate water in advance,

then click bowl 1  or bowl2  to select the bowl you want to

operate. then keep clicking the "SET" switch  , until the display shows "CLR" that means open

Clean System. After cleaning, click the SET switch  once more, the display shows "OFF" that means close Clean System. Ditto for operating the other bowl. When cracks aren't clean, use the provided towel to clean remaining dirt and wipe up any water stain.

D. Slush/Margarita Wine Slush/Ice Cream /Frozen Drink Function: First

click bowl 1  or bowl 2  to select bowl you want to operate.

Then keep clicking the SET switch  until the display shows SLS that

is used to switch on Slush System. Then you can click "+"  to make

slush/ice cream harder and can also click "-"  to make slush/ice cream softer. The machine will automatically save the setting after 5 seconds. Ditto for operating the other bowl.

6.4 Dispensing slush

Pull down handle and slush will outflow from the bowl



Attention: When distributing slush for the first time or after a long stop, please extrude and waste a little and then distribute to customers.

6.5 Emergency



Warning: In an emergency, the machine should be turned off by the power button and power cut off.

If frozen, cut off power and ask for specialized people to handle. If fire, clear

nearby area and ask for professionals.

7. Cleaning and maintenance



Before cleaning or maintaining external parts, please ensure main switch is off and unplug.

Any cleaning or maintaining protection supplies needs to wear(gloves.glasses chanson)based on local safety standard

When cleaning or maintaining. operate as below.

Wear protective gloves against an accident.

- Do not use solvent or flammable substance
- Do not use tough or metal sponge to clean machine or parts
- Do not spray liquid to nearby area.
- Do not wash parts in the bowl!
- Do not dry parts in furnace or microwave oven.
- Do not immerse the machine in water
- Do not spray the water to the machine directly.
- Warm water and approximate cleaner can be used (abiding local law and rules)

"After finishing, make sure that all protective covers and guards that have been removed or opened and sent back in place and properly secured.

Cleanliness and hygiene have to be taken carefully and forcibly based on local standard to ensure qualified slush



Cleanliness and hygiene have to be taken carefully and forcibly

based on local standard to ensure qualified slush Bowl needs to be cleaned everyday at least and abiding local laws and regulations And

cleaning times may be added based on different products More

information,please consult manufactures.if machine will not be confused

day continuously please clean distributing taps with clean rag. Even though machine's components stainless steel, plastic and rubber are easy to clean as well as its shape , it is still necessary to prevent germs and fungi reproduction due to halfway cleaning. When the plug is not pulled out or the total switch is in the downstate. Do not clean maintenance the machine.

7.1 Empty Bowl

Before cleaning bowl, empty bowl

If it is the first time to use, no need to make it empty .

This manual just explains one bowl as sample

Other bowl's operations are the same based on related their buttons

Please set the bowl to "clean state", then pour material from bowl.

7.2 Disassembling the dispensing tap



Fig.8

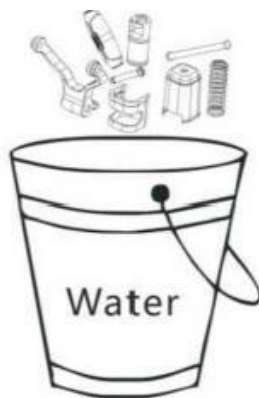

Fig.9

Do not disassemble taps when there are products or liquid in bowls.

7.3 Move out bowl and cover

Move out every bowl to clean the machine.

Move out the bowl as below steps

1.Lift the top cover upward and take it out. Pull the tank upward and outward to completely remove it from its seat.

2. Screwing off the nut.

3. Takeout stirrer and the seal of stirrer. See Fig.10.

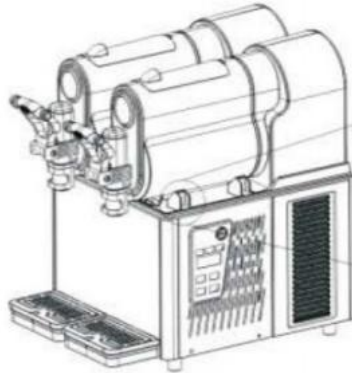

Fig.10

7.4 Clean and disinfect parts

All dismantled parts should be cleaned thoroughly



Importance: Cleaning way has abide by local current hygiene standard.

Please operate as below instructions:

Pour water in the container. mix sanitizer with water (Add 2% sodium hypocrite to water)

Sponge with sanitizer clean bowl, cover and evaporator thoroughly clean with water thoroughly

Add sanitizer to another container.

Put dismantled parts in sanitizer 30 minutes. Reclean with water thoroughly.

Make the parts dry.

Assemble machine under 7.5 instruction.

Sponge with sanitizer clean the roof and heartstrings the immaterial.



Fig.11

Retain 30 minutes

Clean bottom surface with water 2-3 times by the sponge. Put cover at clean area and dry it by rag

Ban cleaning by water or disinfecting before taking away the cover

7.5 Reset cleaned parts

All disinfected parts have to be reassembled carefully. some parts need to be lubricated to work normally.

Gasket (A) on stirrer. see Fig.12

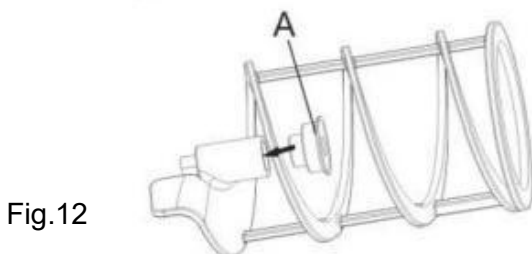

Fig.12



Importance: Check gasket in regular if broken. Please replace new one. Replace gasket(A) once at least one year



Fig.13

After gasket (A) is installed in, coat the inside of gasket (A) with the provided grease. see Fig.13

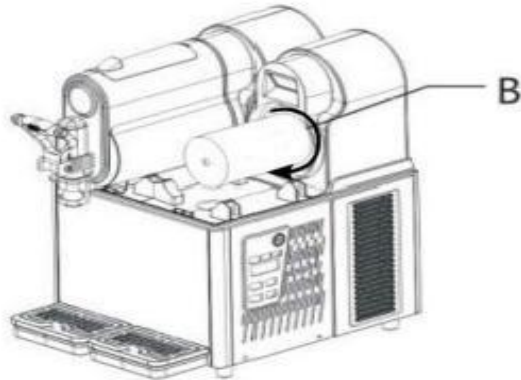

Fig.14



Install seal(B),lubricate entire surface with grease as arrow marks.see Fig.14



Put stirrer into tank

Attention: Adjust the stirrer to appropriate location.

See fig.14-1

Replace the seal ring.When motor part leaks,you need to replace the seal ring Take out the motor bracket connected to the motor and then replace the head seal ring (washer of axis,seal of axis).When replacing.You need to add some grease.Then install the motor bracket connected to the motor.

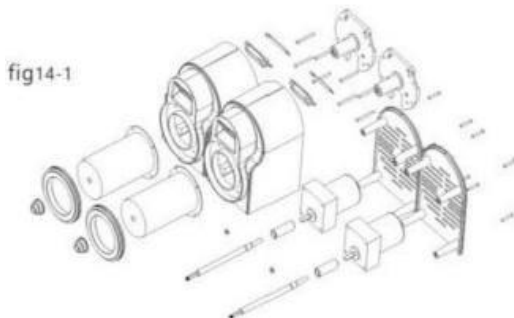

Fixed the stirrer and install the bowls as Fig.15

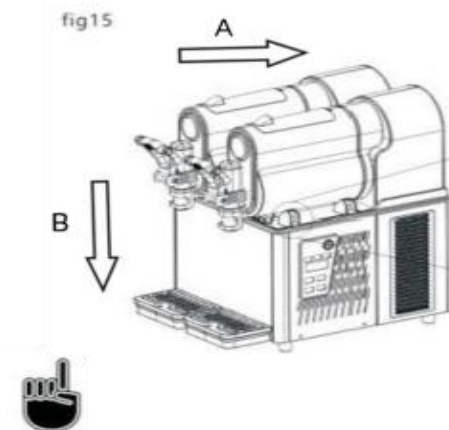

Attention: Adjust the bowls to appropriate location.

Install the roof as Fig16

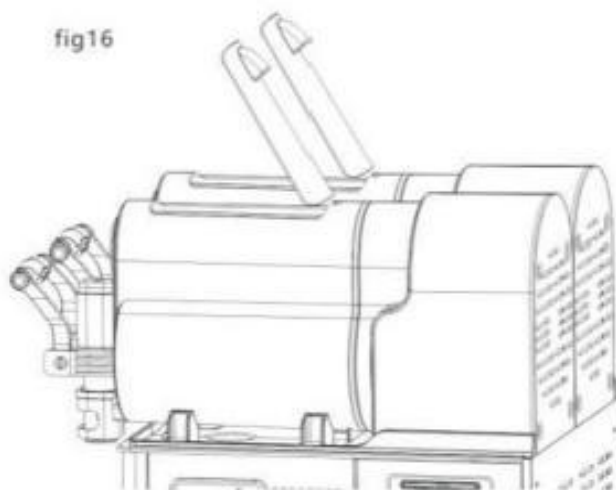

Press down top roof until it fits in .

Install taps as below instructions as Fig.17

1.Lubricate totally with grease.

2.Insert screw when taps are steady.

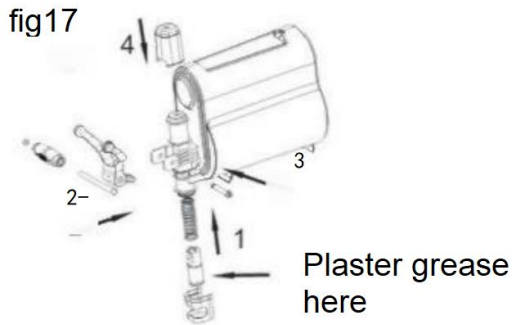

Attention: Install all parts under figures' instructions. Please apply grease well to prevent liquid leakage.

7.6 Clean step

Before using this machine, below cleaning steps are needed

1. Fill bowl with water fully.
2. Start machine only in cleaning mode and stir for 5 minutes. Stop machine and open tap to clean containers.

7.7 Cleaning drip tray

Drip tray should be emptied and cleaned everyday



Attention: All machine drip trays should be cleaned. Drip tray needs to be emptied and cleaned.

Take out drip tray by lifting from top.

Wash the tray and grid separately with lukewarm water. Dry all of the components. Fit the tray back in place and press to secure it to the machine. Reposition grid on top of the tray



When machines stopped, clean by wet rag and dry the parts.

7.8 Replace bulb



Only when machine power handoff unplugged bulb can be replaced

According to below figure, open the small back panel, replace the LED bulb, after assembled put the panel back, confirm closed well.

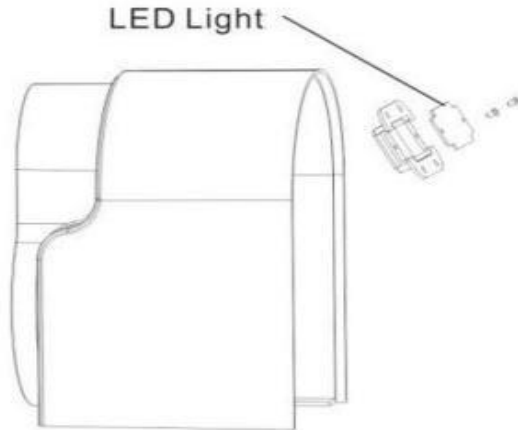

Fig.19

7.9 Clean condenser

Only professionals can clean condenser. They know all operating steps well using approximate device and abide by local law and regulation strictly. Condenser needs to be cleaned in regular.

Warning: Machine sharp surface may hereafter dismantling safety protection parts. Dirty condenser will weaken machine function.

Condenser can be seen after taking out safety protection parts.

Even though only one plate (front or back or side) is not installed the machine is also banned to use. Operator banned to clean condenser

Protection parts need to be positioned by Screwdrivers

7.9.1 Cleaning condenser of one-bowl slush machine

Safety protection parts need screwdrivers to fasten and dismantle.

1. Loose side panel screw.
2. Take out side panel
3. Dismantle safety protection parts. Brush dust from condenser surface

with dry brush as Fig21

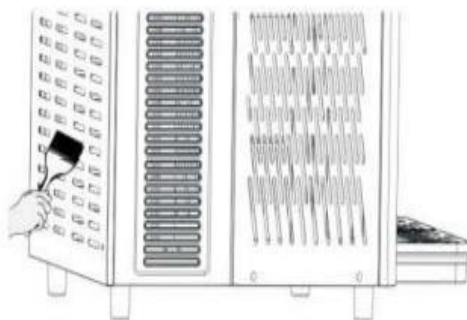

Fig.21

After cleaning condenser, reposition safety protection parts

7.9.2 Cleaning condenser of two-bowl slush machine

According to the following instructions: 1. Loose 3 screws of the back plate

2. Loose 5 screws of the side plate.

3. Take out the side panel.

Dismantle safety protection parts.

Brush dust from condenser surface with dry brush as below.

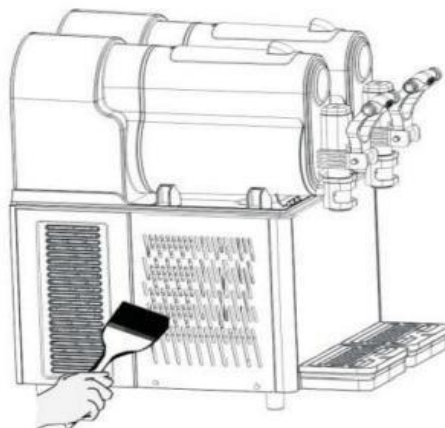

Fig.22

7.10 Scheduled maintenance

This machine needs to be maintained by professionals in regular (at least 1 year).

Regular maintenance can ensure machine and its parts in good safety state

Any broken part need to be replaced with original manufacturer When any parts machine are malfunctioned or broken machine is banned to use. The user can not maintain the machine himself

8. Waste treatment



Electronic waste need to be handled according to 2002/96/EC

But wastes need to be dismantled and classified and useful parts should be recycled

Above rubbish bin reminds people classifying rubbish. Treating wastes correctly protect our environment.

9. Troubleshooting

Trouble	Potential problems	Solution
Can not turn on the machine	No input power	Insert the plug into the appropriate socket
	Not pressed the switch	Press the switch
Outlet leaking	Outlet without Vaseline	Add Vaseline on outlet
	Outlet broken	Change the outlet
Bowl leaking	The bowl not be installation in suitable position	Check the bowl position
	No Vaseline on bowl's seal ring	Add Vaseline on seal ring
	Bad seal ring	Change the seal ring
The stirrer not working	Not turn on the main switch	Turn on the main switch
	Bowl inside freezing	Run off the main switch and let the ice melting

The machine not making slush	not turn on the main switch	Turn on the main switch
	Not turn to the "SLS" mode	Turn to the "SLS" mode"
	Heartsickness is not suitable	Adjust the slush thickness
	Condenser too dirty/poor ventilation	Clean the condenser
	Slush machine approach in the hot position	Put the machine to a cool position
The stirrer makes noisy	Stirrer's seal ring installation badly	Check and replace the seafaring
	No Vaseline on seal ring or seal ring broken	Add Vaseline or change the seal ring
No slush coming out from the outlet	Bowl inside freezing melting	Turn off the main switch and let ice melt

9.1 Fault Codes and Solutions For Slush Machine

9.1.1. When the temperateness is connected, "LL" is displayed. Check whether the temperature sensor is installed well or the connecting wire is damaged or broken, replace the temperature sensor.

9.1.2 The temperateness is short-circuited and it displays "LL". Check whether the temperature sensor is installed properly, or the connecting wireless is damaged and connected together, or the temperature measured by the temperature sensor exceeds 60°C, replace the temperature sensor.

9.1.3 When the grid voltage is too high, the machine stops working and generates an alarm code "E1 Err".

9.1.4. When the grid voltage is too low, the machine stops working and generates an alarm code "E2 Er".

1. It is recommended that customers buy a voltage stabilizer, so the voltage can be used.

within a reasonable range

2. Change voltage alarm parameters without generating voltage alarm

I. In the power-on state, long press the "Settings" button for 3 seconds to enter the setting menu, and the window flashes as



II. Then click the "Settings" button, the window flashes as



II. Then click the "Slush softness" button to set the value to 0

IV. Wait until the display does not flash, indicating that the setting is successful

9.1.5. The measured motor current is too high, the current channel generates an alarm and protects shutdown, the display code is E3 Err.

1. If the mixing shaft is blocked and shutdown protection is caused, it will automatically restart after 5 minutes
2. If the motor is broken and rotates very slowly or cannot rotate, you need to place a new motor
3. So change motor current alarm parameters and stop if no alarm degenerates, and then check whether the motor is rotating

I. In the working state, long press the "Setting" button for 3 seconds to enter the setting menu, the window flashes as

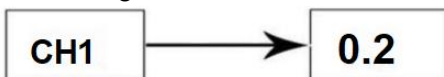

II. Then click the "Setting" button, the window flashes as



III. Then click the "Setting" button, the window flashes as



IV. Then click the "slush softness" button to set evaluate to 0

V. Wait until display does not flash, indicating that the setting is successful.

10. Intelligent electronic valve system

Electrical diagram-XRJ3LX1

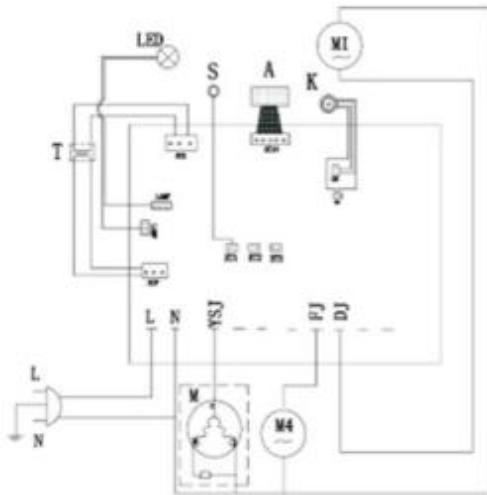

- M Compressor
- M4 Cooling fan
- M1/M2/M3 AC geared motor
- K Main switch
- A Touchpad
- T Transformer
- LED LED light board
- S Temperature sensor
- F Electromagnetic valve

Electrical diagram-XRJ3LX2

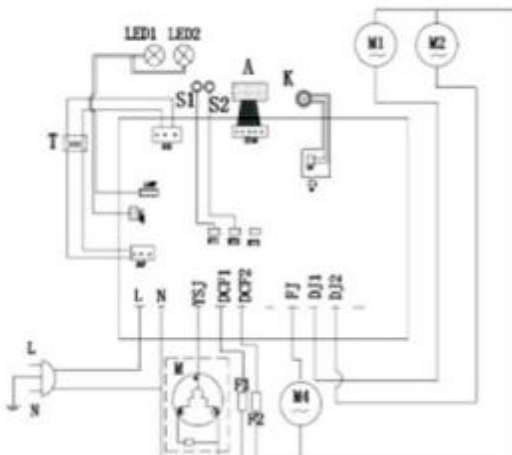

- M Compressor
- M4 Cooling fan
- M1/M2/M3 AC geared motor
- K Main switch
- A Touchpad
- T Transformer
- LED1/LED2 LED light board
- S1/S2 Temperature sensor
- F1/F2 Electromagnetic valve

11.Slush machine explosive diagram

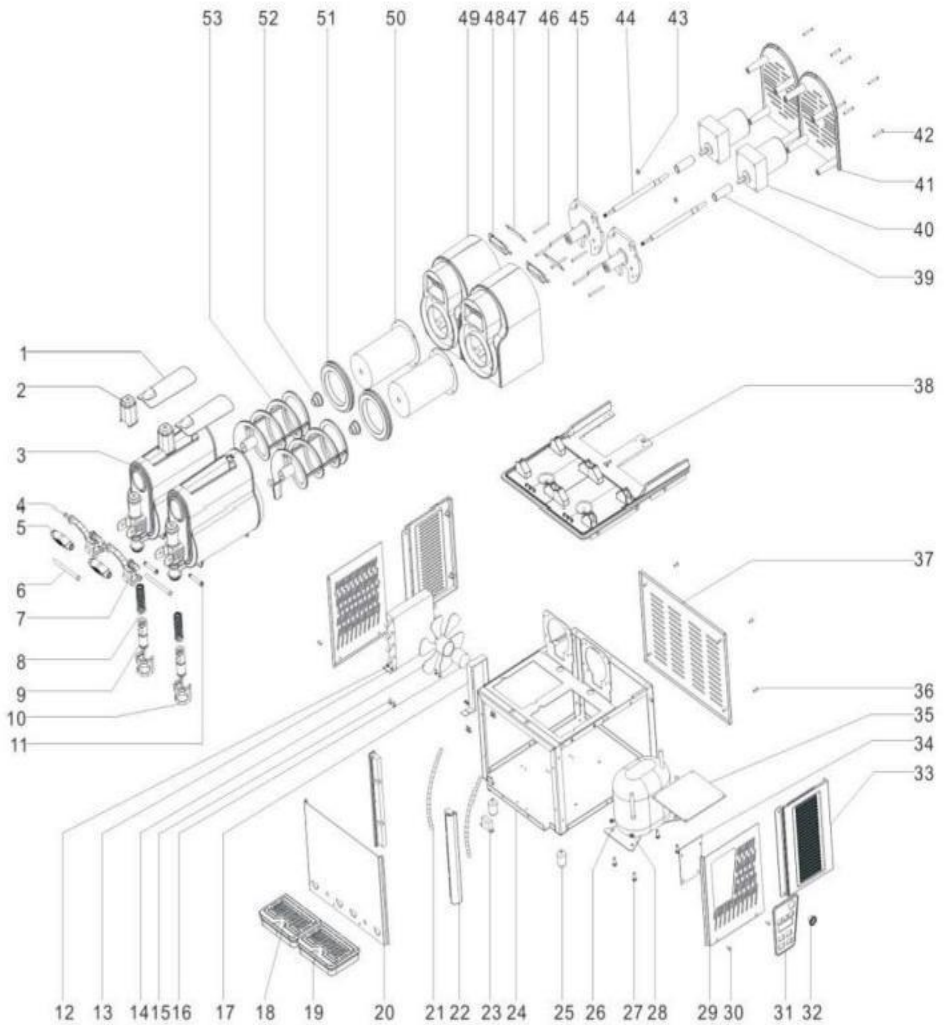

Code	Parts Name	Code	Parts Name
1	Roof	29	Panel
2	The roof for handle	30	Side plate fixing screw
3	Tank	31	Control panel
4	The main Pin of the hand lo	32	Switch

5	Handle	33	Back panel
6	Pin of the handle	34	PCB board
7	Wrench bracket	35	Drainboard
8	Spring	36	Plate nut
9	Plunger	37	Backboard
10	The cover of handle	38	Base panel for 2 tank
11	Vice-Pin of the handle	39	Copper bush
12	Hex nut	40	Motor
13	Condenser	41	The back panel for motor
14	Fan	42	Back mountaineering
15	The fixed bolt for fan motor	43	Spring
16	Fan motor	44	Stirring Rods
17	The holder for fan motor	45	The holder of motor
18	The roof of Terawatt	46	Motor fixed screw
19	Drip tray	47	The main board for light
20	Front panel	48	Lamp shade
21	Pipe	49	The holder for stirrer
22	Jambe	50	Evaporator
23	Transformer	51	Tank seal ring
24	Main body frame	52	Seal of mixing auger
25	Rubber fool	53	Mixing auger
26	Compressor	54	
27	The screw compress	55	
28	The Nut of compressor	56	

VEVOR[®]

TOUGH TOOLS, HALF PRICE

Technical Support and E-Warranty Certificate

www.vevor.com/support