

VEVOR

Affordable. Reliable. Home Improvement.

ICE CREAM MACHINE

Model:BJH288SR1B-Z BZH288SR2JB-Y

VEVOR

Affordable. Reliable. Home Improvement.

ICE CREAM MACHINE

MODEL:BJH288SR1B-Z BJBH288SR2JB-Y

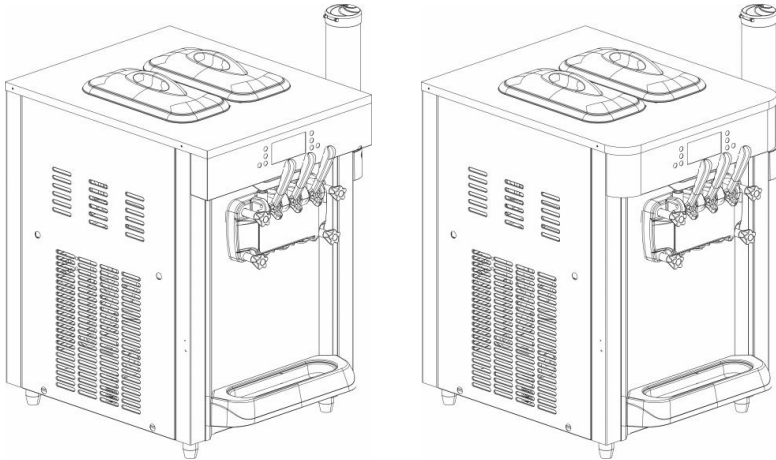

<Picture Only For Reference >

This is the original instruction, please read all manual instructions carefully before operating. VEVOR reserves a clear interpretation of our user manual. The appearance of the product shall be subject to the product you received. Please forgive us that we won't inform you again if there are any technology or software updates on our product.



Warning-To reduce the risk of injury, user must read instructions manual carefully.



CORRECT DISPOSAL

This product is subject to the provision of European Directive 2012/19/EC. The symbol showing a wheeled bin crossed through indicates that the product requires separate refuse collection in the European Union. This applies to the product and all accessories marked with this symbol. Products marked as such may not be discarded with normal domestic waste, but must be taken to a collection point for recycling electrical and electronic devices

Important safety instructions

Warning Notes



Warning: Contents that may cause death or serious injury if used incorrectly.



Notice: Contents that may cause personal injury or damage to articles if used incorrectly.

Precautions Before Use



warning

- In the event of gas leakage, do not touch the machine and the leaky circuit breaker. Instead, open the window for ventilation immediately, otherwise it may cause an explosion.
- Do not use flammable objects near the machine, otherwise it may cause a fire.
- Do not step on the machine and hang or place heavy objects on it, otherwise it may cause damage to the machine and personal injury.
- Do not insert fingers and rods into the heat dissipation port, otherwise it may cause personal injury and affect the heat dissipation effect.
- Do not touch electrical parts or switches with wet hands, otherwise it may cause electric shock.
- Children should be supervised to ensure that they do not play with the machine.

Electrical Safety Matters

- It is necessary to entrust the electrical construction unit to connect the ground wire. Otherwise, an electric shock accident may occur in the event of a malfunction or leakage.
- The power supply shall be consistent with that on the nameplate. If shared with other appliances, it may cause a fire accident.
- The power cord shall not be damaged, broken, processed, bundled, stretched, bent or twisted. Otherwise, the broken power cord may cause an electric shock or fire accident.
- Do not spill water directly on the machine, otherwise it may cause an electric shock.
- If the supply cord is damaged, it must be replaced by the manufacturer, its service agent or similarly qualified persons in order to avoid a hazard.

Installation Precautions

- When assembling and disassembling parts, please turn off the control power switch. Otherwise, accidentally touching the starting machine may cause personal injury.
- Please disinfect your hands and fingers during operation. Otherwise, it may endanger human health.

Use Environment (Conditions)



Warning

- Place the machine on a level and firm ground. Otherwise, it may cause toppling, noise, and excessive vibration.
- Do not use it in places with high humidity or where it will get wet with water. If it is used in a wet place, it may cause a short circuit of the machine.
- Do not use it in places with a lot of sulfuric acid, such as hot springs, or in places with a lot of salt, such as near a bay. Otherwise, it may cause internal corrosion of the machine, resulting in machine failure.



Notice

- Please place the machine in a well-ventilated place. Do not place items on the top cover of the machine, otherwise it will cause noise. The left, right and rear sides of the machine must ensure a space of more than 1m, otherwise it will affect the heat dissipation and the production capacity of the machine.

Please do not at the ambient temperature of direct sunlight or near heating appliances. Please use the machine place it under 5~38°C.

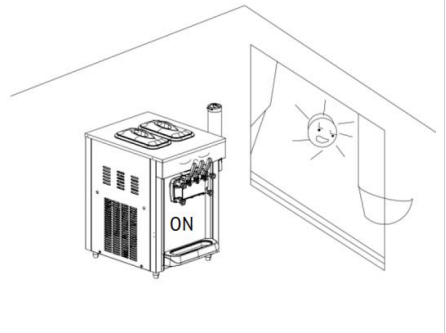
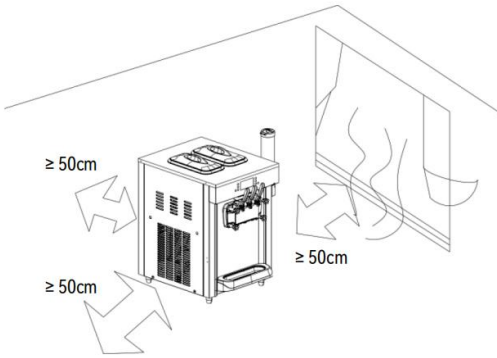

Storage Instructions



warning

- When not in use for a long time, unplug the power plug. Otherwise, the service life of the power cord may be reduced.



Notice

- When the machine is abnormal or malfunctioning, turn off the power switch. Otherwise, it may cause machine failure.
- In the place where the temperature may be lower than 0°C, please pay attention to the drainage operation. Otherwise, it may cause water leakage.
- Please carefully dry the water in the hopper and the freezing cylinder, and put the hopper lid on for storage after drying.
- Please disassemble the parts to the smallest unit and keep them in a clean place, which also helps to prolong the service life of the parts.

•**Note:** This appliance contains flammable refrigerant and foaming agent cyclopentane.

Please avoid contact fire when you transport and use it.

Please ask professional for servicing when the machine broke down.

Please send it to your local appointed disposal station when you discard it.



WARNING: During use, service, and disposal of the appliance, please pay attention to a symbol similar to the left side, which is located on the rear of the appliance (rear panel or compressor) and with yellow or orange color. It's a risk of fire warning symbol. There are flammable materials in refrigerant pipes and compressors. Please be far away fire source during use, service, and disposal.

Product Overview

Product Schematic

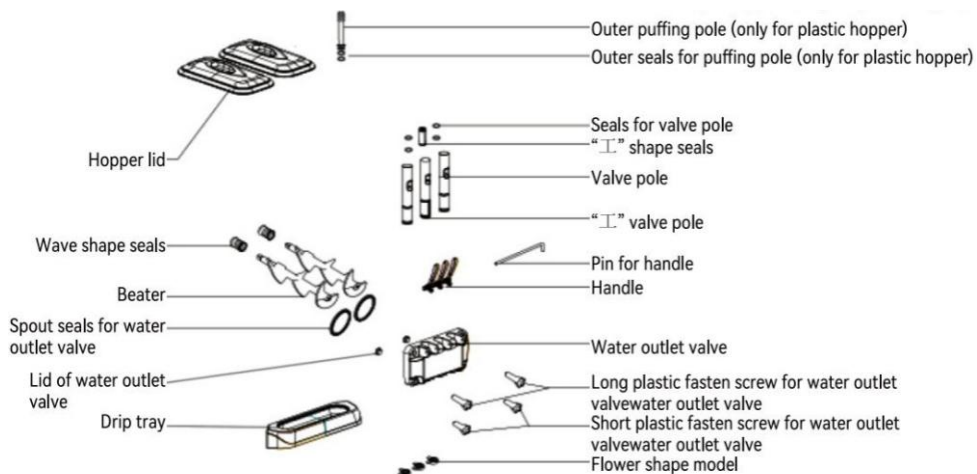
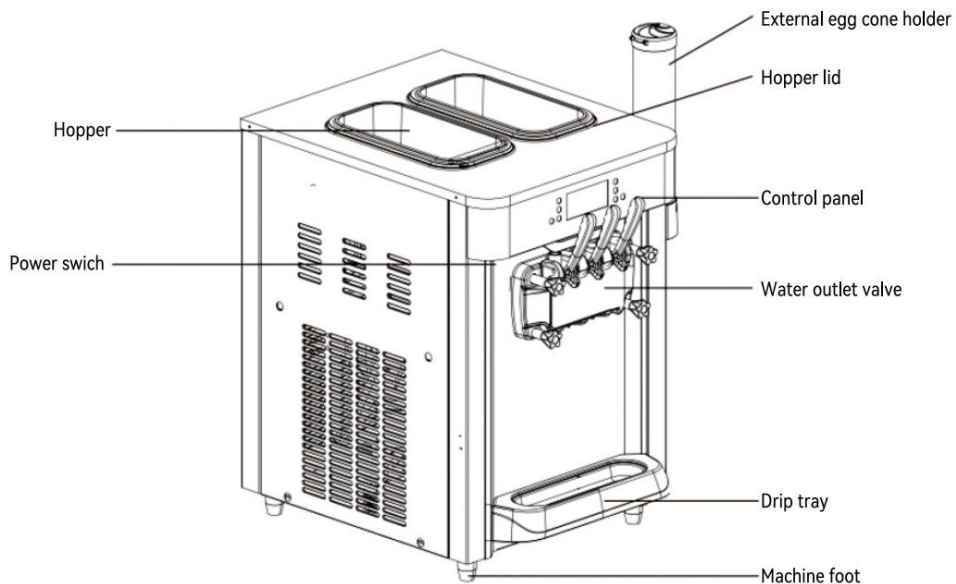

Corrugated seal ring *2, 1-shaped seal ring *1, 0-shaped seal ring *4, D-shaped seal ring *2, Discharge port with cover *2, Magic cap *3, External cone holder *1, Toothed belt *1, Puffing pole *2

Product Specifications

Model	Rated Voltage	Rated Input Power	Refrigerating Capacity
BJH288SR1B-Z	AC120V 60Hz	1550W	22-30L/H
	AC220-240V 50Hz	2200W	
BJH288SR2JB-Y	AC120V 60Hz	1860W	
	AC220-240V 50Hz	2350W	

Installation Notes

Before installing the parts, please refer to the "Cleaning Method of Parts" to clean the parts.

Assembly of Valve Pole

Install O-rings and sealing rings on the two types of feeding rods, and assemble them as shown in the figure. When assembling the I-shaped sealing ring, apply a little lubricant to the head of the sealing ring.

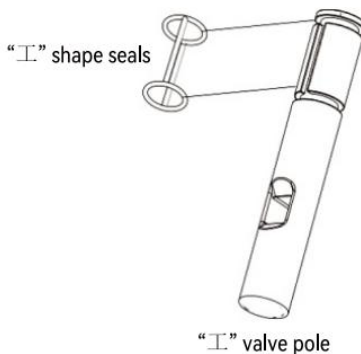
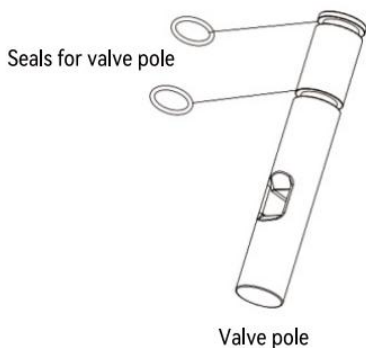

Assembly of the Agitator

1. Apply lubricant to both ends of the wave-shaped sealing ring.

2. Install the corrugated sealing ring directly.
3. Insert the agitator into the freezing cylinder, and slowly rotate by hand to insert the square head of the agitator into the square interface of the reducer.

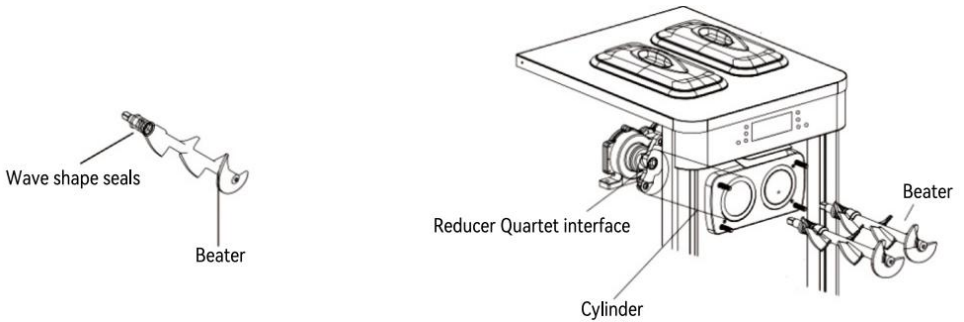

Assembly of Discharge Door

1. The valve pole is installed in the three chutes corresponding to the discharge door, and the I-shaped feeding rod is installed in the middle. The plum-shaped molding head is installed in the slot below the chute (you can apply a little lubricant to the front end of the valve pole when installing it).
2. After the valve pole is installed, insert the boss at the front of the handle into the groove of the valve pole. Then pass the handle cross-pin along with the handle through the cross-pin hole in the discharge door.
3. Install the discharge door D-shaped sealing ring and the discharge door small cover in the corresponding groove.
4. Lift up the punching switch board, pass the discharge door through the four plastic head fixing bolts, and then fasten the four discharge door fixing plastic screws evenly and diagonally according to the long screws on the top and the short screws on the bottom.

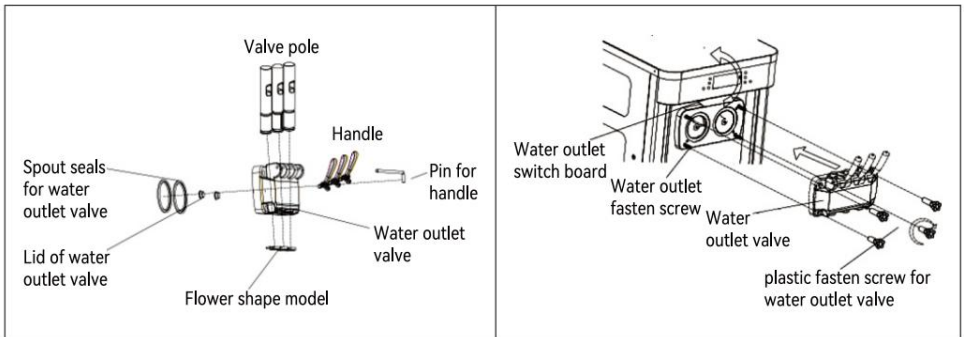

Operation Guide

Name and Functions of Operating Parts

Except for the setting button, the other buttons can be pressed with a click. (To prevent malfunction, the button needs to be pressed slightly harder.)

- When switching between buttons, press the stop button before switching.
- Safety function: For safety reasons, other buttons cannot be operated without the discharge door installed.

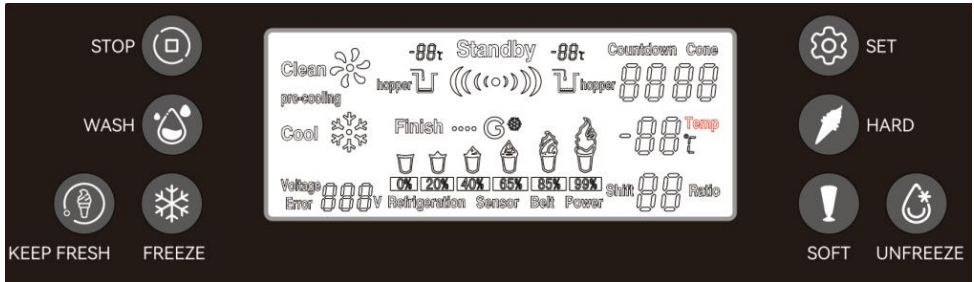





- STOP: The machine stops working
- WASH: The machine goes into cleaning mode
- FREEZE: The machine goes into cooling mode
- KEEP FRESH: The machine enters the fresh-keeping mode
- SET: The machine enters the parameter setting mode
- HARD/SOFT: Add and subtract in parameter setting mode
- UNFREEZE: The machine goes into defrost mode (model BJH288SR2JB-Y only)

Detailed Explanation of LCD Display

Display shows	Contents
	<p>It indicates that the machine is in the cleaning state.</p> <p>At this time, only the agitator in the refrigeration cylinder is rotating. Add water to the hopper to clean the refrigeration cylinder of the machine.</p>

<p>Standby (((•)))</p>	<p>It indicates that the machine is in standby mode. At this time, long press the setting button to set the performance of the machine and other operations.</p>
<p>-88 Temp °C</p>	<p>It indicates the temperature of the machine's return air pipe. When the temperature is below -25 °C, the machine will alarm, which does not affect the performance of the machine.</p>
<p>Cone 88</p>	<p>It indicates how many cones the machine has made in total. The handle will push up the punching plate and touch the internal micro switch, it will be recorded once, and the micro switch will make a ticking sound when it is touched.</p>
<p>-88 hopper</p>	<p>The upper temperature display indicates the hopper temperature. If the hopper appears strobe, it means that the machine is out of material.</p>
<p>Countdown 88</p>	<p>It shows how many minutes left until the next automatic cooling after the material forming of the machine enters the stop state. During this period, refrigeration can be manually turned on or will start automatically after feeding.</p>
<p>88% Ratio</p>	<p>During normal refrigeration work, it displays the molding percentage of the material in the machine's refrigeration cylinder, except when the machine is in the setting state, it displays the current shift of the machine. When it reaches 99%, it means that the material has been formed, and the machine will automatically stop if it continues to run for a period of time.</p>
<p>Cool ❄️</p>	<p>It indicates that the machine is in cooling state. When it reaches 99%, it means that the material has been formed, and the machine will automatically stop if it continues to run for a period of time.</p>

<p>pre-cooling</p> <p>Cool </p>	<p>It indicates that the machine is in a fresh state. At this time, the cooling cylinder and the sump will be cooled.</p>
<p>   Clean</p>	<p>It indicates that the machine is in a defrosted state. At this point, the cooling cylinder is heated.</p>

Operation Process

Preparation of Raw Materials

NOTE: Before adding ingredients, try to make sure that there is no residual water in the freezing cylinder from cleaning.

1. Pull down the handle, and pour a small amount of raw materials into the hopper when the valve pole is raised.
2. There will be water flowing out of the discharge port. When the raw material flows out, please turn the handle upward and the valve pole slides down.
3. The ice cream machine must use special ice cream powder or slurry raw materials. When using ice cream powder, please strictly follow the deployment ratio on the ice cream material packaging bag_(generally, 1 kg of material is mixed with 2.5 to 3 kg of pure water). After adding water, please stir evenly, let the water and ice cream powder fully mix, and let it stand for 5 minutes before pouring it into the hopper.

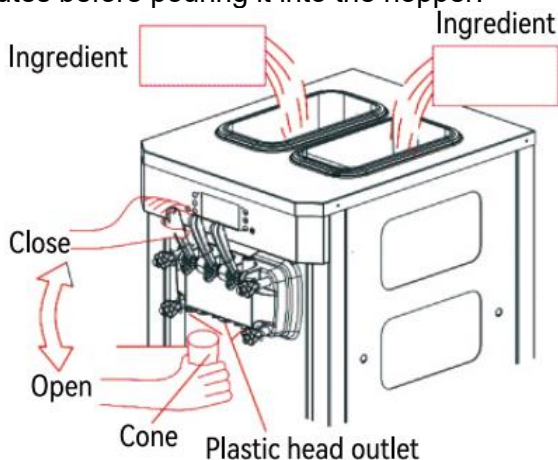

Raw Material Filling

1. Do not insert the puffing rod before pouring the ingredients, please pour about 6 liters of ice cream ingredients into the two hoppers, and press the WASH button. (A maximum of 8 liters of ingredients can be poured into the hopper.)

2. If the raw material is put into the hopper (no air bubbles are generated), please adjust the puffing rod to the closed position, and then insert it into the feeding hole of the hopper.

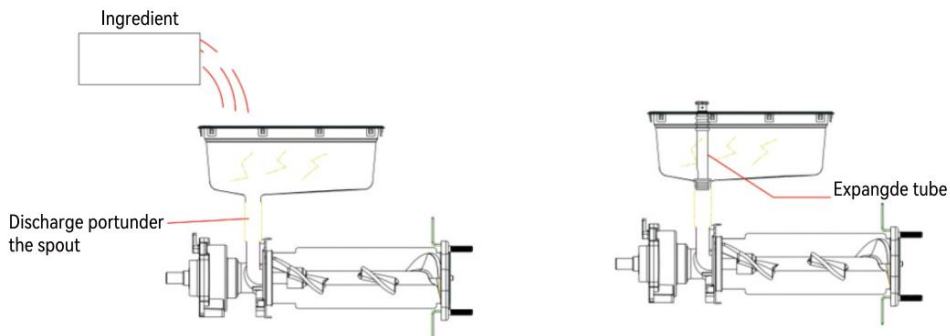

3. Pull down the middle handle (the valve pole rises), measure 400cc of raw material from the measuring cup in the material tank, and take it out, pour it back into the material hopper and cover the material hopper cover.

Note: Please use a measuring cup that has been cleaned and disinfected.

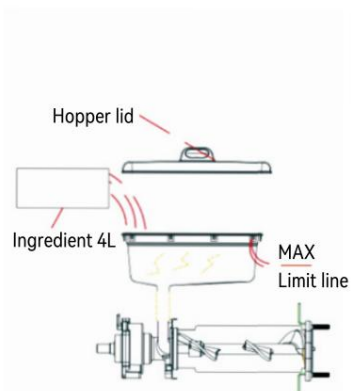
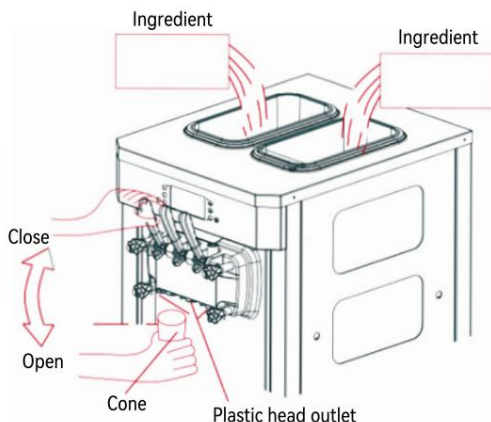

Parameter Setting

1. In the standby state, press and hold "SET" for 5 seconds, the digital tube at the shift position flashes and the word "**88%**" lights up. This state is the hardness adjustment state. Use the "HARD/SOFT" button to adjust

the hardness of the ice cream. And the range of the hardness is: shift 1-12. If the hardness is adjusted too much and the ice cream is too hard, sometimes it may not come out, please pay attention.

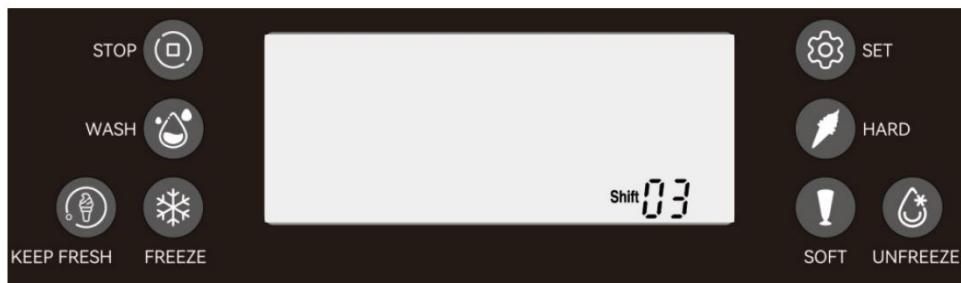

Hardness Adjustment Status

2. In the hardness adjustment state, press and hold "SET" for 5 seconds, at this time, the four-digit number at the cup count flashes and the word "cone" lights up. In this state, press and hold the "SOFT" button for 5 seconds, and the cup count value is reset to zero.



Cup Count Record Clear Status

3. In the state of clearing the number of cups, press and hold "SET" for 5 seconds. At this time, the four-digit number at the stop time flashes and the word "Countdown" lights up. This state is the stop time adjustment state, and the stop time can be modified by pressing the "HARD/SOFT" button. The range of stop time is: 1-15 minutes. The factory default is 5 minutes.



Stop Time Adjustment Status

4. Press and hold "SET" for 5 seconds in the stop time adjustment state, this state is the pre-cooling and fresh-keeping temperature setting state, at this time, the pre-cooling and fresh-keeping temperature can be modified by the "HARD/SOFT" button. The range is: 1-15°C. The factory default is 10°C

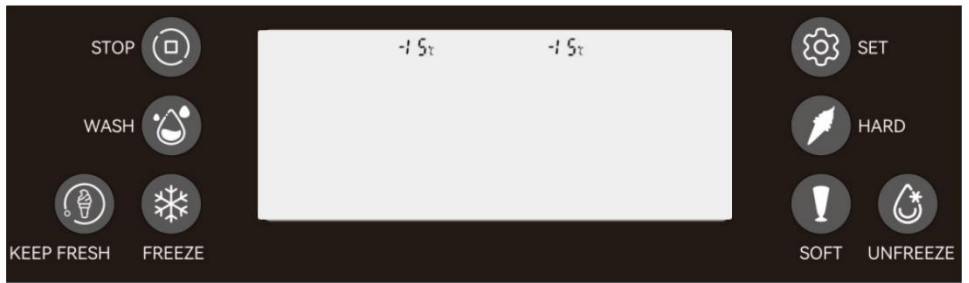

Pre-cooling and Fresh-keeping Temperature Setting Status

Making Ice Cream

1. Connect the machine to the power supply, turn on the power switch of the machine, fill the hopper with drinking water (the machine can be used for the first time with boiling water, which can be used for sterilization), and then press the WASH button to work for about two minutes. Discharge all the water on cleaning mode and repeat cleaning the machine 2-3 times until the water discharged from the discharge port is clean.
2. At present, the market generally adopts ice cream whey (which can be used directly) or ice cream powder mixed with water. If you use ice cream powder, please mix it strictly according to the mixing ratio on the ice cream powder packaging bag (generally, the mixing ratio is 1 kg powder with 2.5-3 kg pure water). Set aside for about 30 minutes. Note that please add water in strict accordance with the proportion of ice cream powder. After mixing, it is very important to stir and stand, which will directly affect the yield and taste of ice cream.
3. Confirm once again that the cleaning water is completely drained, and pour the prepared ice cream into the hopper on the top of the ice cream

machine (be careful not to agglomerate). Press the WASH button (the ice cream machine stirs the ice cream material again to make the ingredients more uniform) after about 1 minute, press the FREEZE button to enter the cooling mode (note that in any case, ensure that the two material hoppers are full, and the minimum cannot be lower than the position of the feeding port, otherwise it will cause the machine to alarm for material shortage, or even damage the machine).

During the production process, the display shows the cooling mode.

Generally, when the molding ratio reaches more than 80%, the ice cream has been formed and can be discharged. When the molding ratio is 99%, the machine will automatically stop. To get ice cream: Take a cone or cup, put it under the discharge port of the discharge door, press the handle with your hand, and rotate the cone with the other hand.

Remaining Ingredients to Keep Fresh

If there are still unused raw materials in the hopper after the machine is used, it is recommended to take out the remaining materials and store them in the freezer or refrigerator. You can also click the "KEEP FRESH" button after use to start the machine's fresh-keeping function.

Freezing Cylinder Solid Ice Cream Thawing(model BJH288SR2JB-Y only)

1.Before cleaning the ice cream machine, if there is still solid ice cream in the freezing cylinder, you can click the "UNFREEZE" button to enter the ice cream machine thawing mode. In this state, the solid ice cream in the freezing cylinder can be quickly melted into liquid, which is convenient for the remaining material in the freezing cylinder to be taken out.

2.If the freezing cylinder freezes due to the high shift level or the unequal proportion of raw materials during use, the ice cream machine will get alarm 55. At this time, you can click "UNFREEZE" to quickly solve the freezing cylinder freezing problem and make the ice cream machine resumes normal operation.

Cleaning and Maintenance

How to Clean the Spare Part

- When using it for the first time or not using it for a long time, please clean the spare parts first.
- Please use food detergent and cleaning brush to clean the parts that have been dismantled.

Notice:

- Do not damage parts or lose parts during operation.



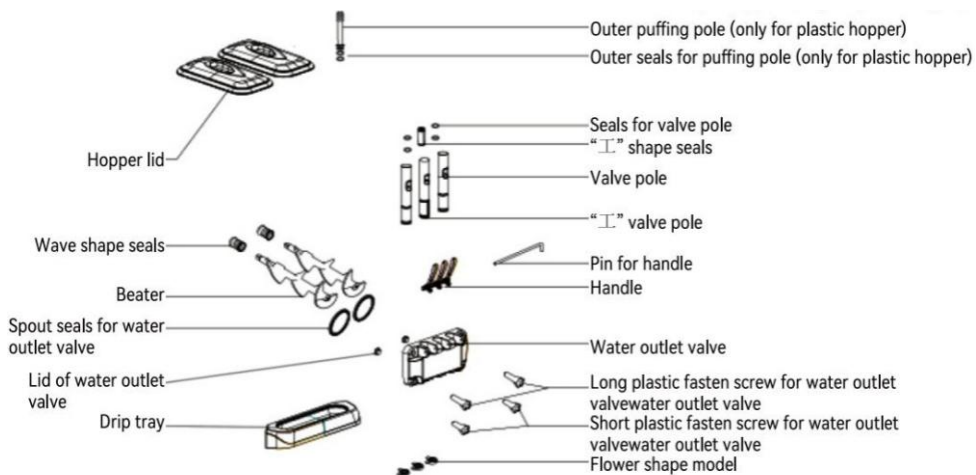



- Do not wash the resin part with hot water or dishwasher. Otherwise it may cause deformation.
- Please do not soak the parts in detergent or bactericidal solution in the bubble parts for more than 30 minutes. Otherwise it may cause deterioration.

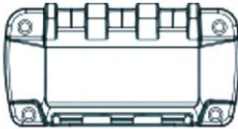

- Especially the following spare parts that are easy to accumulate residual material, please clean them carefully with a soft brush.

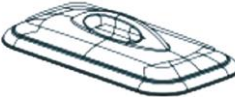
Notice:

1. Some spare parts have sharp edges, please pay attention.
2. Carefully clean the beater with a cleaning brush, including the middle part.

 <p>Water outlet valve</p>	 <p>Valve pole</p>	 <p>“工” valve pole</p>	 <p>Hopper lid</p>
 <p>Beater</p>	 <p>Wave shape seals</p>	 <p>puffing pole (only for plastic hopper)</p>	

How to Clean Ice Cream Machine

1. Please use food detergent to clean the parts. For details, please read "Parts cleaning method" carefully.
2. Please install the cleaned parts on the ice cream machine. Please read the "Installation Instructions" carefully for details.
3. Please turn on the control power switch of the ice cream machine. At this time, the ice cream machine enters the standby state.

Notice:

After the assembly is completed, do not press any switches without adding water or raw materials to the material basin, otherwise it may cause the machine to malfunction.

4. Please inject an appropriate amount of food detergent into the hopper, and then inject an appropriate amount of water into the hopper, press the WASH button, and the agitator starts to rotate. Wash for 3 to 5 minutes.

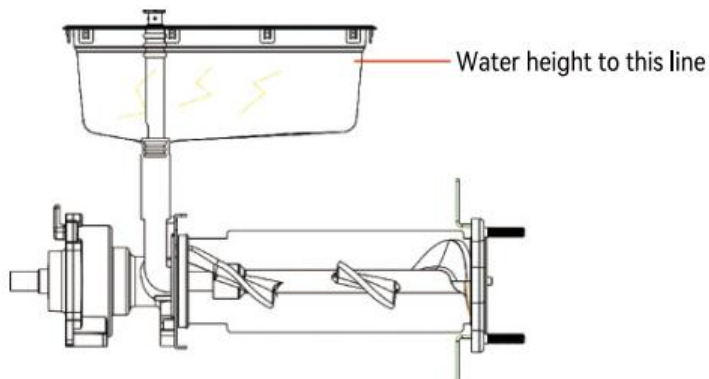

5. Please drain the cleaning water. After cleaning for 3 to 5 minutes, press down the three handles, then catch the water with a bucket, and repeat the cleaning 2 to 4 times. (Do not wash again with the water that was used last time).

Note: Do not place the bucket on the water box, it may damage the water box.

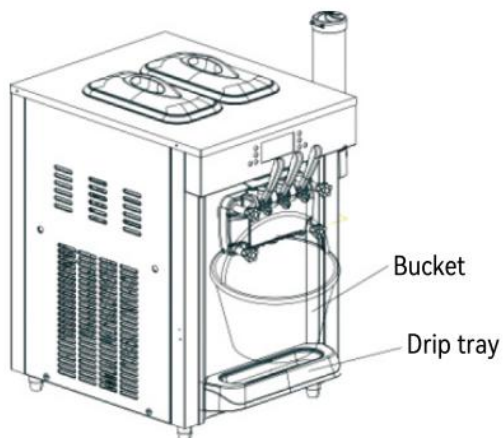

Consumable Parts

1. Even if there are no visible damages on the sealing ring, it may still cause problems such as "ice cream leakage" or "poor sterilization". Therefore, please consider replacing it approximately every three months. Regularly replace with new products. Even within the replacement period, if any damage or issues occur, please replace promptly.

2. If the mixer wears out excessively, it may cause inconsistencies in the softness of the material inside the refrigeration cylinder and difficulty

dispensing some materials. Therefore, please consider replacing it approximately every six months.

3. Regularly replace with new products.

4. If severe wear occurs within the replacement period, please replace promptly.



Feeding Rod O-ring



H-shaped Seal Ring



Corrugated Seal Ring

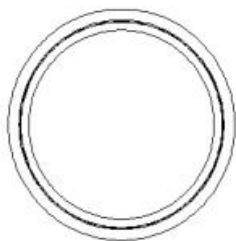

Plastic Head D-ring

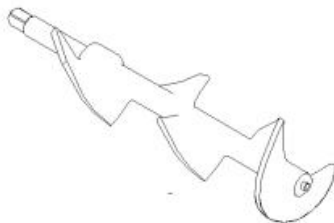

Stirrer

Ice Cream Machine Maintenance Methods:

Discharger Outlet

Please carefully wipe the ice cream on the discharger and sterilize thoroughly with disinfectant.

1. Please spray disinfectant to the discharger 3-5 times to flush the ice cream sticking to it.

2. Please use a paper towel sprinkled with disinfectant to wipe the ice cream stuck to the discharger.

3. Visually confirm whether there is any residual material at the outlet of discharger, if any, repeat all previous cleaning operations.

4. Finally, please spray disinfectant for 3-5 times to the outlet of discharger again.

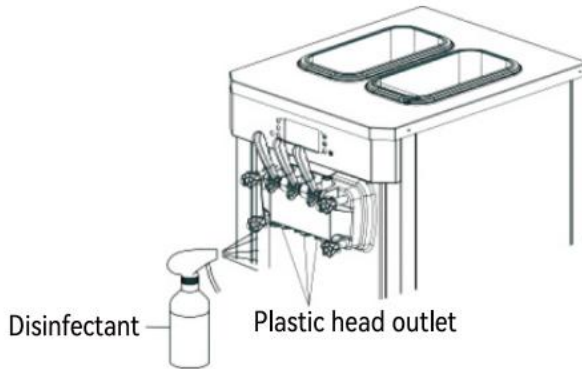

Ice Cream Machine Body

1. Be sure to disassemble and clean it every two weeks. When disassembling and cleaning, please discard all the remaining raw materials inside the machine.
2. After disassembling and cleaning, assemble the parts and wash them in hot water for five minutes to ensure sterilization.
3. Please wipe with a dry, soft cloth. If the pollution is serious, please add food detergent in warm water, wipe the dirt clean, wipe the residual detergent ingredients.

About the Drainage Pipe

If material is discharged from the drainage pipe, it may indicate that the corrugated sealing ring needs to be replaced. Please replace it yourself. If the issue persists, please contact the sales store or maintenance personnel where you purchased the product.

Maintenance of the External Surface

1. Please wipe with a dry, soft cloth. If heavily soiled, add food detergent to warm water, wipe off the dirt and then wipe off any remaining detergent residue.
2. The bottom part and base of this machine are also prone to contamination, so please clean them regularly.

User Precautions

1. Do not use polish, gasoline, acetone, or hot water, as they may damage the machine's exterior.
2. Absolutely do not pour water or alcohol directly on the machine, as it may cause electric shock or accidents.
3. Check the power cord for damage or breakage 1-2 times a month.

Consumable Parts

As consumable parts may lead to faults such as "ice cream too soft", "ice cream machine leakage", or inadequate cleaning, please regularly replace them according to the approximate standard replacement periods listed in the following table with new products.

Component Name	Required Quantity	Replacement Period
Seals for valve pole	4	3-6 months
“工” shape seals	1	
Spout seals for water-outlet valve	2	
Wave shape seals	2	
Consumable Pars Kit Lid of water outlet-valve	2	3-6 months

Notice:

1. Please do not use polish, gasoline, natural water, hot water. Otherwise, the outer packing of the machine will be damaged.
2. Please never spill water directly on the machine. Otherwise, electricity leakage or accidents may occur. Please check once or twice a month to confirm whether the power cord is damaged or broken.

Clean Condenser

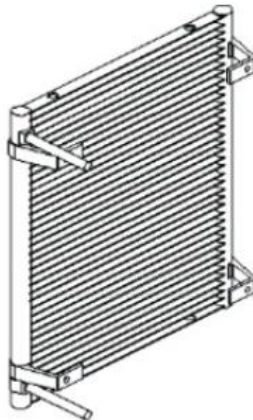

Work for a period of time the condenser will be sticky dust heat, cooling effect will be worse (ice cream production performance is: the same time or hard molded), please must once every three months to clean (if using

the environment is bad, please wash once a month), had better ask professional cleaning cleaning, turn off the power before cleaning, be careful not to damage the condenser fin.

Belt Adjustment

- After the machine is used for a long time, the driving belt of the stirring system may be elongated, so it needs to be adjusted in time.
- In the case of shutdown and power outage, open the side panel and adjust the elastic screw of the belt to ensure proper tightness of the belt.

Notice:

After using for a long time, the driving belt will be elongated and worn normally, which is not within the scope of after-sales service of our company. When the driving belt is elongated, the machine will not work or the hardness of the machine will change and the noise will be large. When necessary, it should be replaced in time. The interval of adjustment and replacement

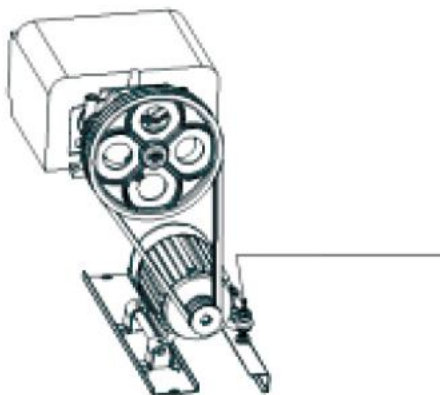

Reducer Fueling

After the machine runs for 6 months, lubricating oil should be added to the reducer, otherwise it is easy to wear and the reducer produces noise, resulting in the machine can not work normally.

Electric principle diagram

BJH288SR1B-Z

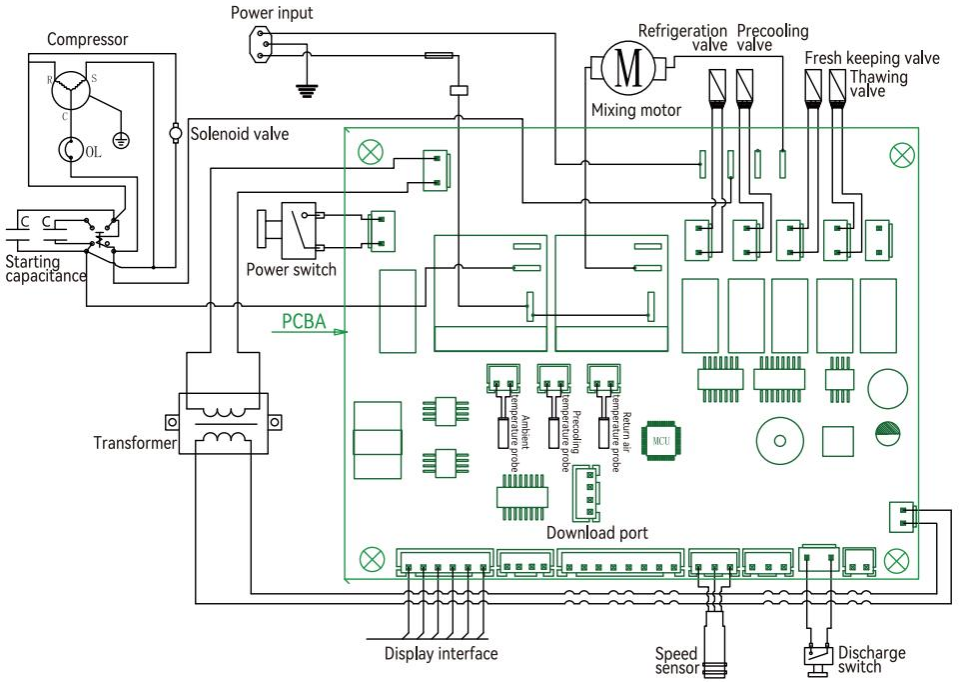

BJH288SR2JB-Y

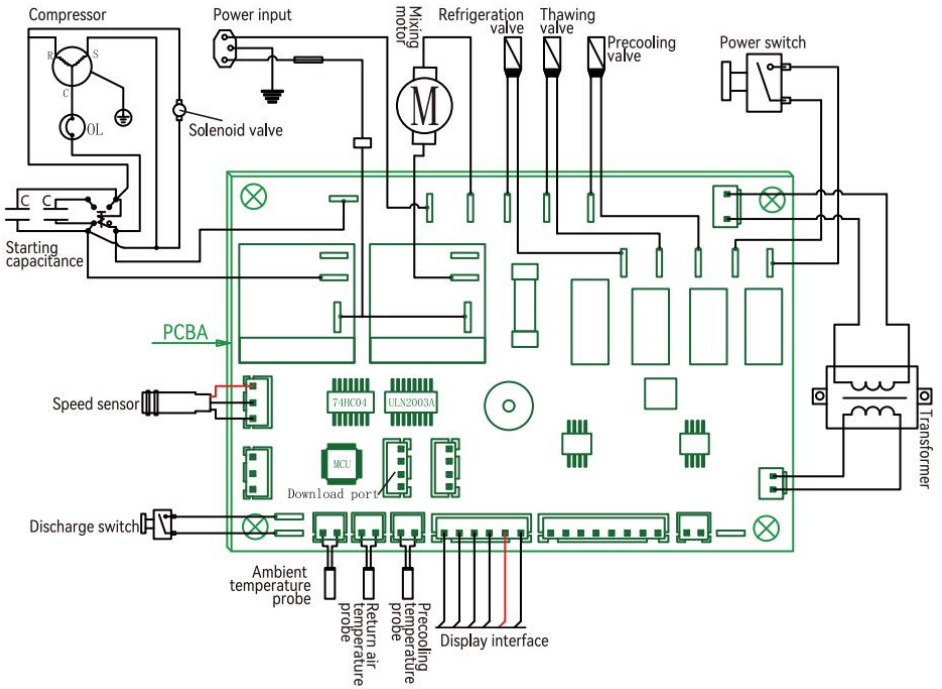

Troubleshooting methods

No.	Fault	Cause	Troubleshooting
1	No display after power on.	1.Whether the power switch of the device is powered on.	Turn on the power switch by yourself.
		2.Check whether the input power cable meets device requirements.	Ask a professional electrician to check.
		3.The wiring inside the machine has been gnawed or loosened by rats.	Ask a professional electrician to replace or fix it.
		4.The PCB board of the device is faulty.	Making service calls or sending mail is handled by professionals.
2	Power switch trip after startup.	1.The input power cable or switch is not loaded enough.	Ask a professional electrician for replacement.
		2.The circuit inside the machine is damaged or bitten by a mouse.	Ask a professional electrician for replacement or bandaging.
		3.The machine is overloaded because the shift is too high.	Make lower shift.
		4.Voltage instability causes circuit parts to be damaged.	Ask a professional electrician for inspection and processing.
		5.Internal short circuit in motor, circuit board or compressor.	Making service calls or sending mail is handled by professionals.
3	There is a leakage after turn it on.	The machine panel has inductive electricity.	Check whether the power input cable is reliably grounded.If there is no grounding cable,ask professionals to add grounding cables.To deal with by yourself.

4	After starting up the discharge head or under leakage material.	1.D seals not fix well.	Check whether the two D type sealing rings of the discharger are installed in the card slot.To deal with by yourself.
		2.The O-ring inside the pole valve is damaged.	Take down the pole valve to check whether the sealing ring at both ends is worn or not.If it is worn,it needs to be replaced.To deal with by yourself.
		3.The fastening screw is not tightened.	Evenly tighten the four screws diagonally.To deal with by yourself.
		4.pole valve disassembly or installation method is not correct, resulting in O type sealing ring damage leakage or water leakage.	Remove gently vertical pull out, installation must be coated with medical vaseline as lubricant, coated in the stem seal ring around,vertical pressure.Do not damage the sealing ring with sharp objects when cleaning.To deal with by yourself.
5	Residual pipe leakage.	1.Discharge head screws are not tightened.	Evenly tighten the four screws diagonally.
		2.Stirrer rear end seal ring is worn.	Replace the rear sealing ring.
		3.Loss of sealing cover at back end of evaporator.	Check usage habits.
6	Abnormal noise after startup.	1.The machine makes a lot of noise when pressing the clean button.	When cleaning noise is larger,add ice cream material will gradually reduce.Normal symptoms do not need to be handled.
			The place is not level,adjust by yourself.
			Screws of coaming plates on three sides of the machine

			are loose.To twist.
			Loose or tight motor belt cause the noise.Ask professional personnel to adjust or replace.
			Remember to add lubricating oil to the reducer after three months of use.Ask a professional to deal with it.
			Abnormal noise of motor or reduction mechanism.Making service calls or sending mail is handled by professionals.
	2.There is a lot of noise when the machine is cooling.		Lack of material when the noise will gradually decrease after feeding.Normal symptoms do not need to be handled.
			Shift setting is too high,adjust shift.
			If the fan is noisy,deal with it according to 3.3.
			If the compressor is noisy,deal with it according to 3.4.
	3.The fan noise.		Check whether there is foreign matter around the fan blade and whether the fixing screw of fan support is loose.Ask professional personnel to adjust or replace.
			Whether the blades chafe the nest shell as they rotate.Ask a professional to adjust the blades.
			The fixing screws of the

			condenser are loose.Ask professional personnel to adjust or replace.
		4.The motor noise.	Motor belt noise.Ask a professional to adjust the motor up or down,or replace the belt.
			Noise is generated when the shift setting is too high.Adjust shift by yourself. Making service calls or sending mail is handled by professionals.
			Noise of motor capacitance.
			Motor noise.
			The motor fixing screw is loose.Ask professional personnel to adjust or replace.
		5.compressor noise.	The condenser is not cleaned for a long time,and the condenser is too dirty,resulting in excessive compressor load.Ask a professional to clean the condenser.
			Internal piping deformation causes vibration noise.Ask professional personnel to adjust or replace.
			Compressor noise.Making service calls or sending mail is handled by professionals.
			Compressor fixing screws are too loose or too tight.Ask professional personnel to adjust.

7	Too soft or too little ice cream	1.Discharge is too frequent.	Wait for the molding proportion to reach more than 90% after the material.Self-debugging use.
		2.Ice cream formula problem.	Adjust the proportion of water.Self-debugging use.
		4.Poor heat dissipation of machine.	To solve the ventilation problem on both sides of the machine,the left and right gap of one meter.To solve by yourself.
		5.low shift.	Adjust shift.Self-debugging use.
		6.voltage unstable	Improve main power line voltage capacity or increase voltage regulator.Ask professional personnel to adjust or replace.
		7.Belt loose or worn	Adjust the belt or replace.Ask professional personnel to adjust or replace.
		8.Machine refrigeration system failure.	Refrigerant leakage or compressor failure.Making service calls or sending mail is handled by professionals.
		9.Too little fabric in the cylinder.	Must ensure that the material should account for two thirds of the cylinder.Self-debugging use.
		10.Check whether the voltage is normal during operation.	Adjust line or add voltage regulator.Ask professional personnel to adjust or replace.
		8	The ice cream was slippery
2.Wrong proportion	Reduce the proportion of		

	and had ice crumbs.		water appropriately.Self-debugging use.
		3.Long time without feeding.	Take out the ice cream properly.Self-debugging use.
		4.shift not enough	Set higher shift.Self-debugging use.
		5.beater wear.	Replace beater.Making service calls or sending mail is handled by professionals.
		6.Material mixing time is too long.	Turn off the power when the feeding interval is too long.Use as you see fit.
9	No ice cream or too soft after shutdown	1.The handle is not in place	When the handle is not down in place,the feeding switch is not closed (G letter is not shining),and the machine is not started.Improve the usage habits by yourself or ask professional personnel to check the feeding switch.
		2.Stop after the first cup of beating soft.	After stopping for a long time, the first cup with water or soft is normal.Improve usage habits or adjust downtime by yourself.
		3.Gear setting is too high or too low.	Adjust gears appropriately.Self-debugging use.
		4.standby time set too long	Adjust standby time.Self-debugging use.
		5.The feeding switch is faulty	Replace the feeding switch.Making service calls or sending mail is handled by professionals.
10	The blender won't pull	1.The water inside the machine has not been released,so the machine	Soaking causes the beater to swell and become stuck in the cylinder.Making

	it out.	has not been used for a long time	service calls or sending mail is handled by professionals.
		2. There is no feeding or water in the machine, press the clean button for a long time	Friction heating causes the beater to swell and become stuck in the cylinder.
11	Alarm of lack of material.	1. The light in cylinder is shining, and there is a warning alarm sound.	Add the material.
		2. Have the material, but still have the alarm.	1. Have foam material in hopper 2. with material, press clean for 5 minutes.
		3. Have alarm not reach the shape rate of 99% after adding material.	Contact us or set by technician.
12	“LL” alarm.	1. Sensor problem.	Check if there is a magnet on the pulley or adjust the position of the sensor or replace it. Solved by technician.
		2. Buzzer sounding, the machine stops working.	Check if the sensor is misaligned or the cable is disconnected. Solved by technician.
		3. The pulley is too shaken.	Check if the pulley fixing screws are loose. Self-tightening.
			Check the reducer whether is damaged. Making service calls or sending mail is handled by professionals.
13	“88” alarm	1. The hopper is short of material.	Please add material in time. Please restart after adding material. Self-debugging use.
		2. Wrong ratio of water to ice cream powder.	The proportion of water is too large. Reduce the proportion of water. Debug

			and use by yourself.
		3.Shift setting is too high.	Set the shift a little lower.
		4.The ambient temperature is high or the air inlet and outlet are blocked.	Strengthen ventilation and remove obstacles in the air inlet and outlet.Self-debugging use.
		5.Poor cooling.	Check whether the condenser is dirty or blocked,whether the exhaust air is smooth,and the refrigerant is lacking.Making service calls or sending mail is handled by professionals.
14	"55" alarm	1.The belt is worn and slipped	Adjust the belt tension or select a reasonable shift.Self-debugging use.
		2.The cylinder is freezing.	Reduce water ratio or reduce shift.Making service calls or sending mail is handled by professionals.
		3.The reducer rotates on one side but does not rotate on the other side.	The reducer is broken.Please replace the reducer.Making service calls or sending mail is handled by professionals.
		4.The motor does not rotate or the motor idling speed is slow.	Making service calls or sending mail is handled by professionals.

		5.The sensor is faulty or the connection line of the sensor is loose.	Making service calls or sending mail is handled by professionals.
15	Reaches "99%" quickly.	1.Unstable voltage.	Check if the voltage is right or install the regulator.Self-debugging.
		2.Beater stuck.	Take the beater and use after burnishing.Self-debugging.
		3.Low motor speed.	Check the motor whether is damaged.Making service calls or sending mail is handled by professionals.
16	Cannot stop automatically after reaches "99%".	1.Belt wear.	Replaced.
		2.Micro switch fault.	Check if the material board is not reset or the micro switch is damaged.Self-debugging.
		3.Electric main board.	Replaced.Self-debugging.
17	Cannot Reaches "99%".	1.Improper hardness level	Adjust the level appropriately.Making service calls or sending mail is handled by professionals.
		2.The ice cream formulation ratio is unreasonable.	Increase water proportion.Self-debugging.
		3.High ambient temperature bad ventilation,or the air intake are blocked.	In a ventilated position,clearing obstacles from air intake.Self-debugging.
		4.Unstable voltage or not enough power supply capacity	Solved by technician.
		5.Bad cooling of cylinder when working without material or no frosting of the return pipe.	Refrigerant leakage.Making service calls or sending mail is handled by professionals.

18	“HH”alarm. m.	Compressor pressure abnormal.	The condenser is too dirty or something wrong with the fan.cleaned or replaced by technician.
19	“UH”alarm. m.	Voltage over-high.	Adjust voltage or increase 6KW regulator.Self-debugging.
20	“UL”alarm .	Voltage over-lower.	Adjust voltage or increase 6KW regulator.Self-debugging.
21	“RL”alarm .	Temperature below - 35°C or temp.sensor break up.	Check operating habits.
22	“RH”alarm. m.	Temperature above 60°C or temp.sensor short-circuit	Check operating habits.

FCC Information

CAUTION: Changes or modifications not expressly approved by the party responsible for compliance could void the user's authority to operate the equipment!

This device complies with Part 15 of the FCC Rules. Operation is subject to the following two conditions:

- 1) This product may cause harmful interference.
- 2) This product must accept any interference received, including interference that may cause undesired operation.

WARNING: Changes or modifications to this product not expressly approved by the party.responsible for compliance could void the user's authority to operate the product.

Note: This product has been tested and found to comply with the limits for a Class B digital device pursuant to Part 15 of the FCC Rules, These limits are designed to provide reasonable protection against harmful interference in a residential installation.

This product generates, uses and can radiate radio frequency energy, and if not installed and used in accordance with the instructions, may cause harmful interference to radio communications. However, there is no guarantee that interference will not occur in a particular installation. If this product does cause harmful interference to radio or television reception,which can be determined by turning the product off and on, the

user is encouraged to try to correct the interference by one or more of the following measures.

- Reorient or relocate the receiving antenna.
- Increase the distance between the product and receiver.
- Connect the product to an outlet on a circuit different from that to which the receiver is connected.
- Consult the dealer or an experienced radio/TV technician for assistance.